



# SERVICE BULLETINS

## FORMER ORDERING FORM

1. Specify machine model and serial number

\_\_\_\_\_

2. Face width of bag (A) \_\_\_\_\_

3. Type of bag producing

SOS\_ Satchel bottom \_\_\_\_\_

4. Slitter slots Yes \_\_\_\_\_ No \_\_\_\_\_

Type of slitter slots

Cam operated \_\_\_\_\_ Rotary \_\_\_\_\_

5. If slitter slots, specify distance from center of plate to the slitter slot.

Short plate (D) \_\_\_\_\_

Long plate (C) \_\_\_\_\_

6. Specify width of thumb tab (B).

7. Which plates require a cutout for thumb tab?

Long former plate\_ Short former plate\_

8. Tube formation

'A' style \_\_\_\_\_ (seam on top of former, bottom folded against seam) - Diagram A

'AN' style \_\_\_\_\_ (seam on bottom of former, bottom folded opposite the seam)

A. Finished Face Width of Bag.

B. Width of Thumb Tab.

C. Width of First (Outer) Flap.

D. Width of Second (Inner) Flap.

E. Bottom Size.

Note: Send actual bag sample.

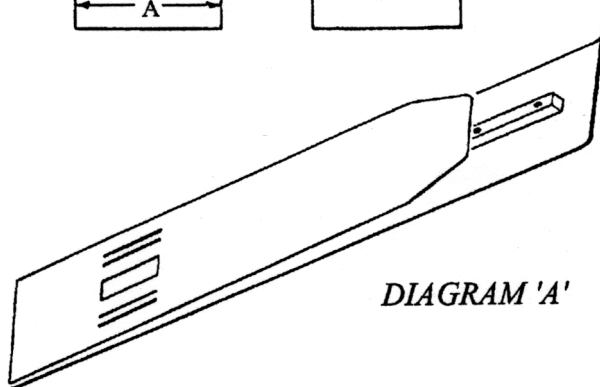
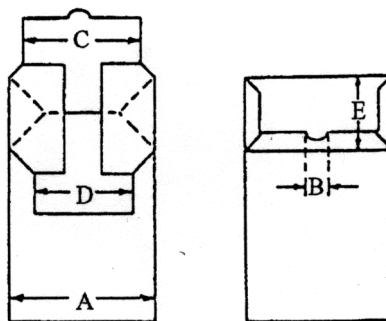

DIAGRAM 'A'

Note: Mounting holes are located with reference to the rib. When no rib is ordered, Weber will not put mounting holes in the former plates. Former consists of: Long plate, short plate and rib.