

CUTOFF CYLINDERS

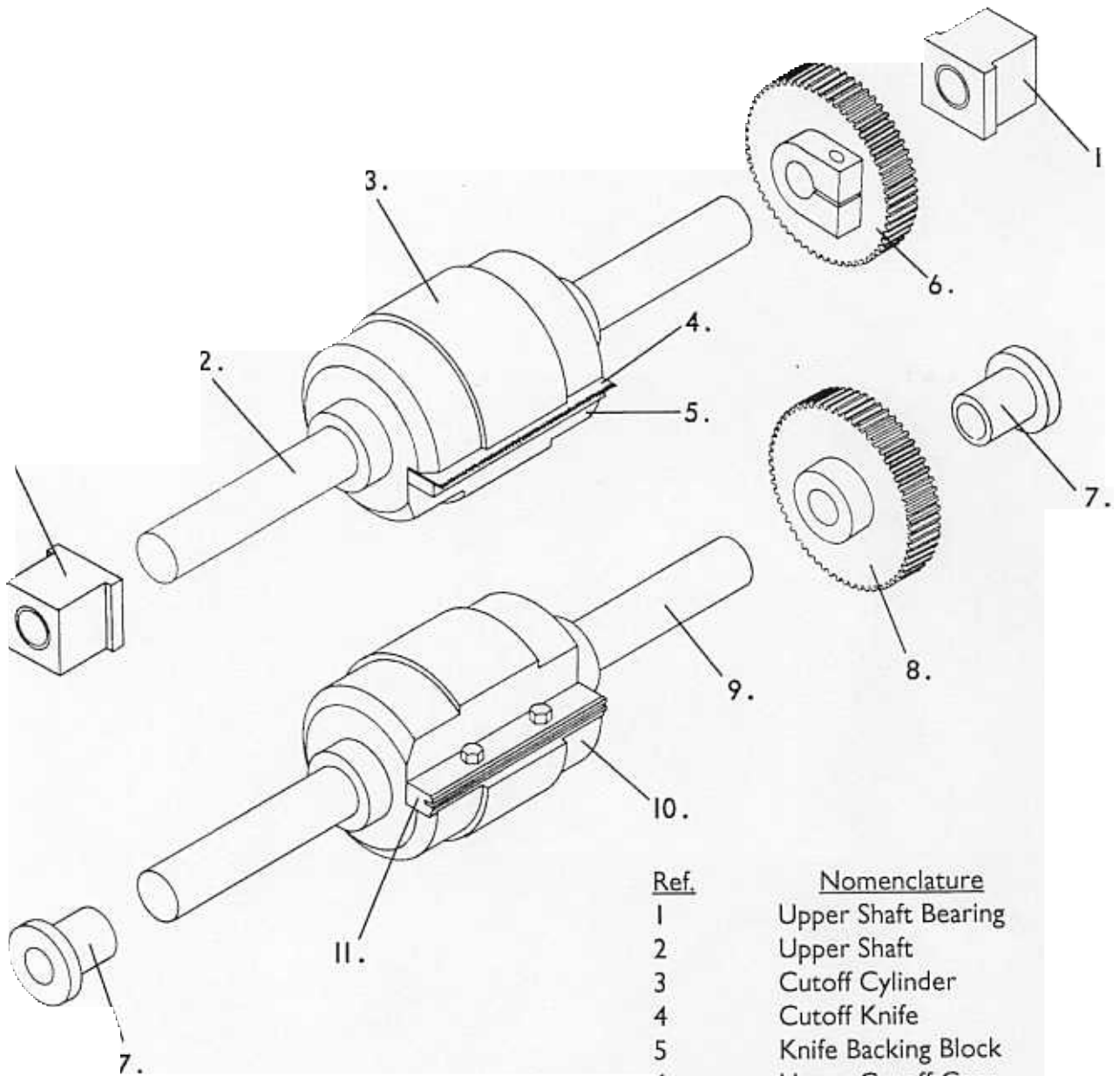

<u>Ref.</u>	<u>Nomenclature</u>
1	Upper Shaft Bearing
2	Upper Shaft
3	Cutoff Cylinder
4	Cutoff Knife
5	Knife Backing Block
6	Upper Cutoff Gear
7	Lower Shaft Bearing
8	Lower Cutoff Gear
9	Lower Shaft
10	Lower Cutoff Cylinder
11	Female Cutoff Block

ADJUSTMENT:

All operations are tied to the cutoff. The knife must be timed to the female block.

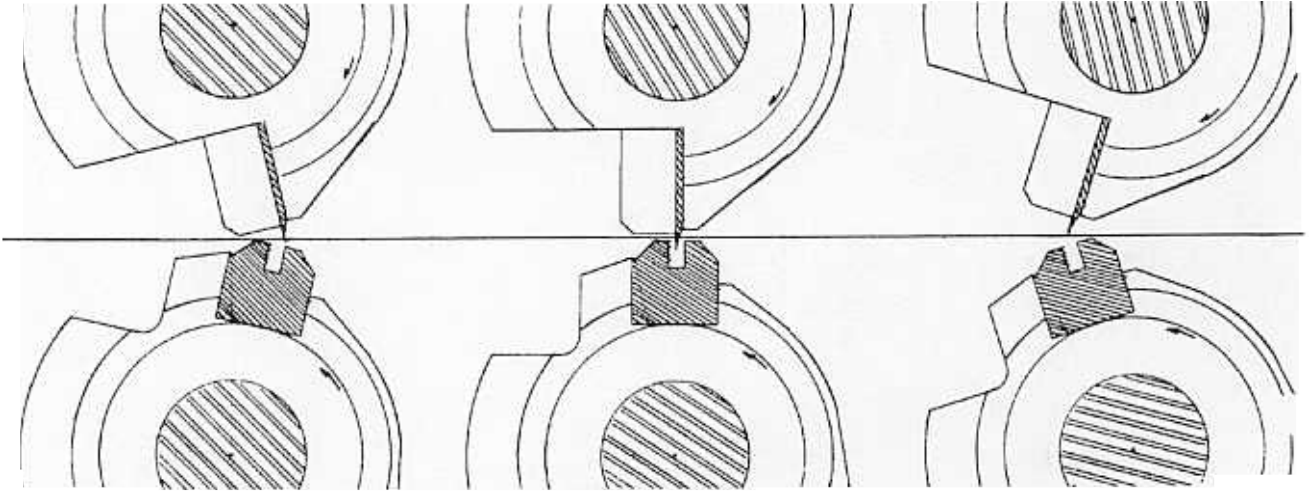

The knife must be timed to just miss the trailing edge of the female block.

This will position the knife in the center of the female block when on a center line between the cylinders.

The knife will miss the leading edge of the female block as it is retracted.